



Description

Use and brief introduction

The product belongs to class I, type B. Non AP or APG device, continuous device. And possesses application part.

YA-03E is designed specially to meet the different demands of the market and according to the common advice of users.

Operating table is used for general operations, it uses electric, with a switch to control its elevation (up/down), easy to operating and it is reliable. The operating table is widely used, easy to operate and adjust with reliable performance, which is a ideal table for different hospital.

General content

Basic data

The technical data should look at Form 1

Form 1: basic data unit:mm

Basic data Model	length	Width	Height range	Distance of elevation
	L	B	h min	S
YA-03E	≥2070	550	700±10	≥300

Standard table configuration includes

NO.	Item	quantity	NO.	Item	Quantity
1	Anaesthesia screen	1 piece	9	Foot plate	2 pieces
2	Shoulder support	2 pieces	10	Long Fixing clamp	2 pieces
3	Body support	2 pieces	11	Fixing clamp	7 pieces
4	Arm board	2 pieces	12	Hand Remote	1 piece
5	Leg support	2 pieces	13	Power line	1 piece
6	Head plate	1 piece	14	oilcan (with oil)	1 piece
7	leg plate	2 pieces	15	User Manual	1 piece
8	Mattress	1 Set			

Gross weight、net weight、 volume

Gross weight:270kg, net weight:220kg, Volume (long×width×height) 1360mm×860mm×880mm.

Safe work loading capacity of YA-03E

The safe working load of the table is 173kg

Commissioning

keeping

Inside its original packing the operating table may be exposed for a period of 15 weeks to environmental conditions within the limits of :

Ambient temperature	-30℃~55℃
atmospheric humidify	≤95%
Atmospheric pressure	500 hPa~1060 hPa

❖ If the operating table has been in the cold, allow it to warm up at room temperature for at least 6 hours before recharging the battery or switching on, to allow any condensation formed to evaporate.

❖ stock in a ventilated place.

Transportation

Upon leaving the factory, the operating table are positioned fit for transportation. In case of further transportation at a later date, we recommend to adjust the operating table into the same position.

❖ In order to transport the operating table,adjust seat and back section in to horizontal position.

❖ Remove the head and leg plates,and detach other accessories.

❖ Adjust the table-top into minimum height.

Attention before using

❖ Please Check the switch, and be sure they can work.

❖ Please confirm all the power line are connected right and safely.

❖ Do not pull or push the shields of back and leg section joints. Check during adjustment that there is no foreign obstacles between shields.

Using adjust

❖ Adjustment of leg plate

The electric leg plate part is controlled by the hand remote.The leg plate is gas spring control.Press down the gas spring,then move the leg plate to the position you need.

❖ Fixing of accessories

There is rail on the both side of the table, you can use the fixing clamp the set up all the accessories.

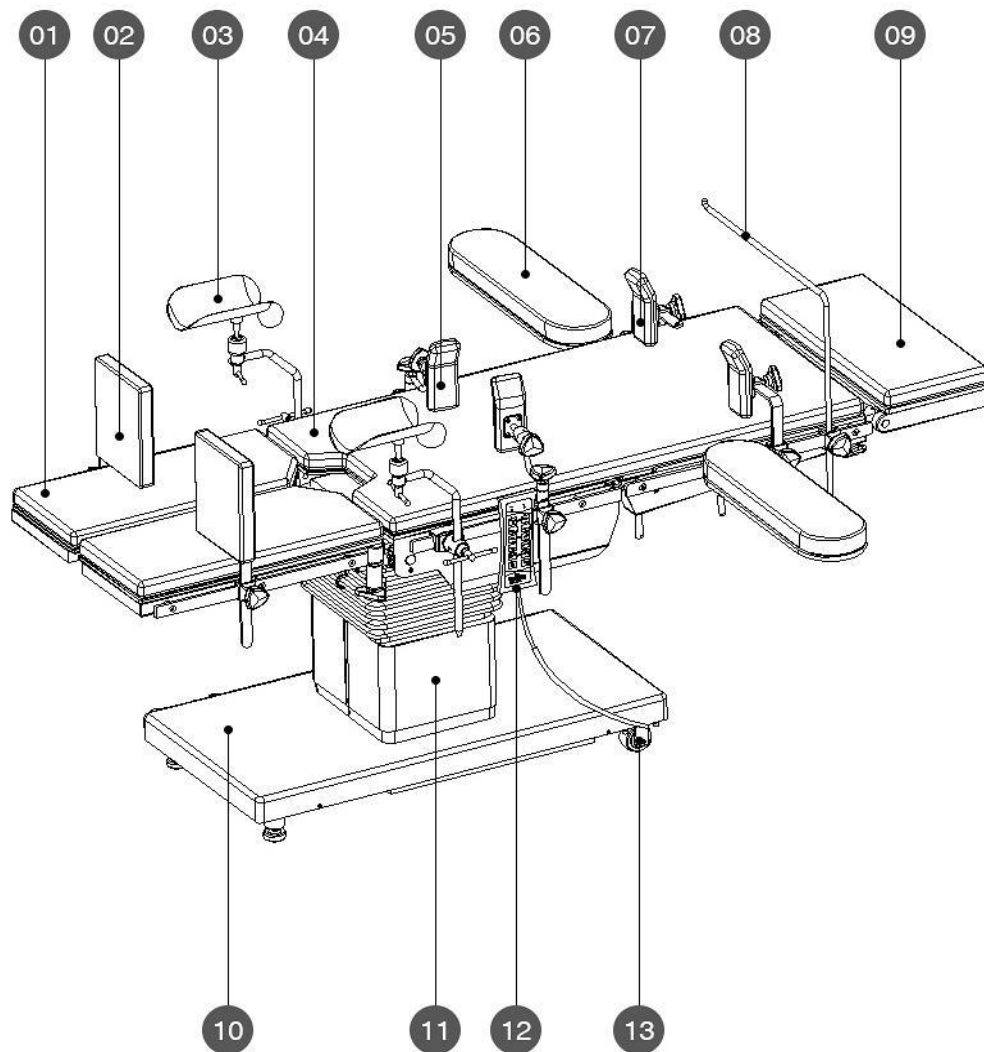

Product information

The operating is formed by head plate and back plate, waist plate, buttocks plate and leg plate

1-Leg plate

2-Foot plate

3-Leg support

4-Body support

5-Arm board

6-Arm plate

7-Shoulder support

8-Anesthesia screen

9-Head plate

10-Base

11-Column

12-Hand remote control

13-Castor

Features

- **Motorized tabletop** is constructed of five-sections (including the motorized fully radiolucent Kidney bridge) and is 2070 mm long. Unobstructed imaging length and 100% C-Arm access without table movement is available. The radiolucent tabletop sections enable viewing of the entire anatomy.
- **Column** supports tabletop and includes lift cylinder, bearings, hydraulic piping, hydraulic actuators for Trendelenburg, electrical wiring and master computer. These components are enclosed by three telescoping plastic or optional stainless-steel column shrouds. The shrouds are of two-piece construction for service accessibility.
- **Base** structure is stainless steel. Four swivel casters, located inside the base cover, facilitate table movement.
- **Auxiliary Control System** (optional) is located on the elevation column.
- **Universal Hand Control** is ergonomically designed, and is the primary interface for table operation. It is constructed of one piece thermoformed plastic that holds and seals the illuminated keypad.



Universal Hand Control

Hand Control Touch Pads for:

- SLIDE HEAD/FOOT
- HEIGHT UP/DN
- BACK UP/DN
- LEG UP/DN
- TREND/REVERSE TREND
- TILT LEFT/RIGHT
- KIDNEY UP/DN
- Lock/Unlock

TABLE OPERATION

Press the desired position touch pad on the pendant hand control or use the optional foot control to articulate the tabletop (refer to Operator Manual).

The following pre-operative actions must be completed before the table can be used

- No objects exist that affect the operations;
- Confirm if all the power lines are connected well, the switch is in “0” condition;
- Move the table to the right place you need;
- Connect the Hand remote with the table;
- Please check the power supply before turning it on;
- Lock the base of the table;
- Fix up the head plate, leg plate and accessories according to the picture.
- The table adopts short-time work, attention: never press one button over 2min.

TABLE MOTION

Ranges of table motion are as follows and are illustrated on the other page

- **Height** 28” to 40”(700-1000mm)
- **Trendelenburg Range** 25°
- **Reverse Trendelenburg Range** 25°
- **Lateral tilt (left/right)** 15°

- **Slide Motion** 300mm
- **Back Section Motion** UP: 75° ; DOWN: 20°
- **Leg Section Motion** UP: 15° ; DOWN: 90° ;Out 90°
- **Kidney Elevator Mechanism** 4.4"(110 mm)
- **Head Section Motion (Manual)** UP: 45° ; DOWN: 90°
- **Loading Capacity** 200kg

Society of Automotive Engineers (SAE) Measurements are based on the metric dimensions; and are therefore approximate.

UTILITY REQUIREMENTS

Power Source:Battery/Electric-Powered Table

Line Power Input:

100/120/220/230-240 V ac (Jumper Selectable),
1 Ø, 50/60 Hz, 4 Amp

Environmental Conditions:

Temperature: 32-122°F (0-50°C)

Relative Humidity (RH): 20-80%

**CUSTOMER IS RESPONSIBLE FOR COMPLIANCE WITH
APPLICABLE LOCAL AND NATIONAL CODES AND
REGULATIONS.**



WARNING – EXPLOSION HAZARD:
Table must not be used in the presence of
flammable anesthetics.

Function of Hand remote

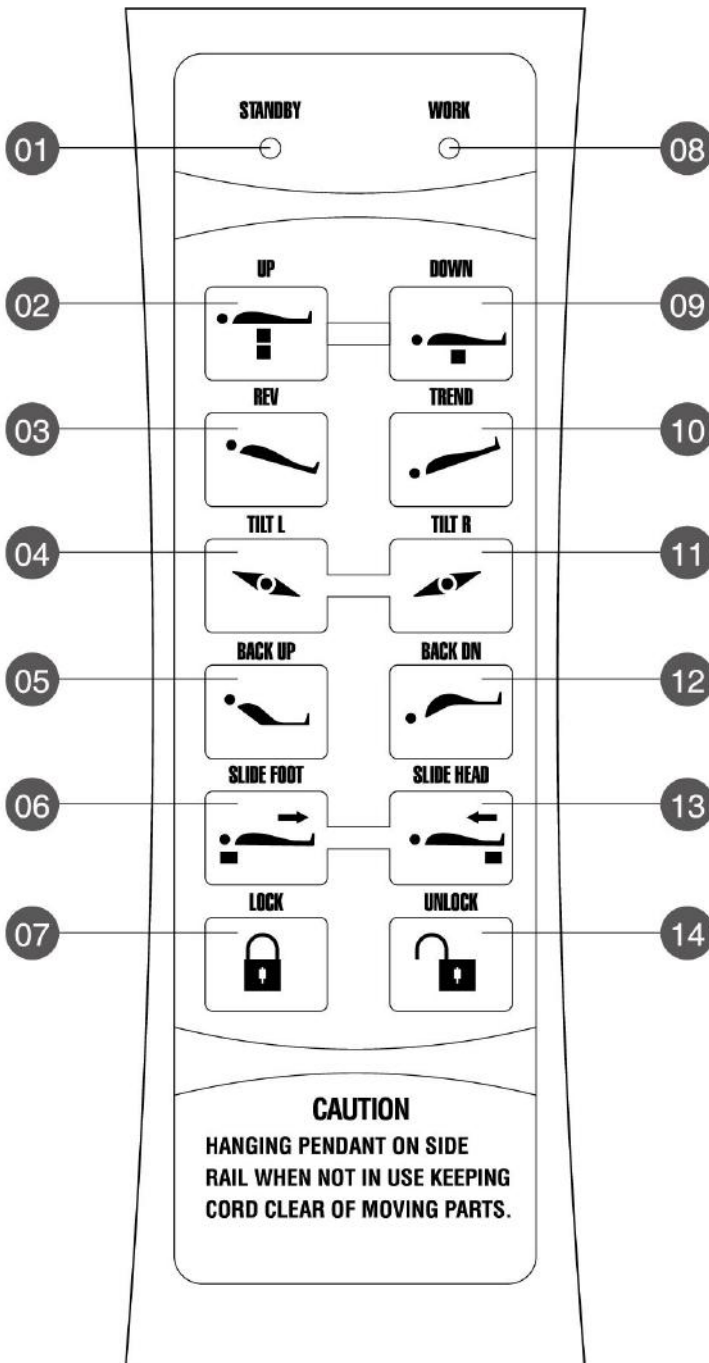

1 STAND BY

Operating table is in the work mode.

2 UP

Raise the table top.

3 REVERSE

Reverse trendelenburg (head down).

4 TILT

Tilt to the left.

5 BACK UP

Raise the back plate.

6 SLIDE FOOT

Move in the direction of the foot plate.

7 SLIDE FOOT

Move in the direction of the foot plate.

8 WORK

Operating table is in the work mode.

9 POWER

The power is on.

10 TRIDENLEBURG

Trendelenburg (head up).

11 TILT

Tilt to the right

12 BACK DOWN

Lowers the back plate.

13 SLIDE HEAD

Move in the direction of the head plate.

14 UNLOCK

Unlock the hand remote,the operating table in the work mode.

Movements diagram

Tabletop elevation(up/down)

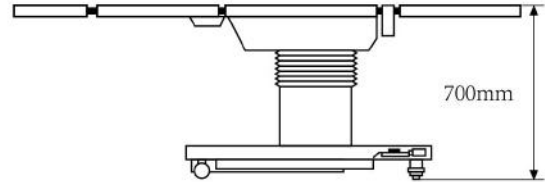
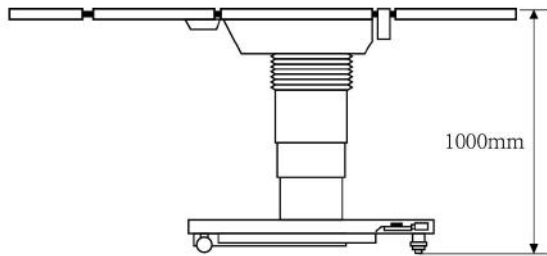

Head plate(up/down)

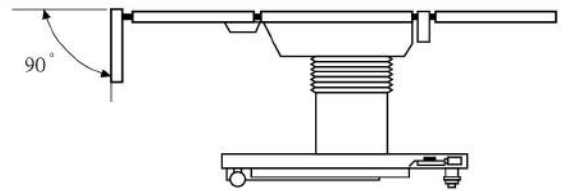
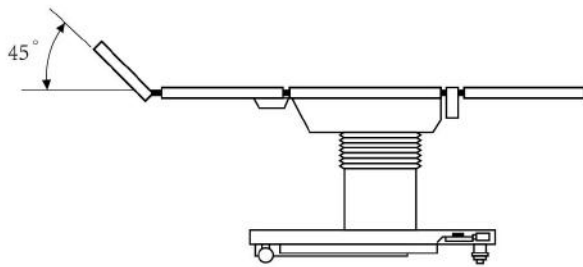

Back plate(up/down)

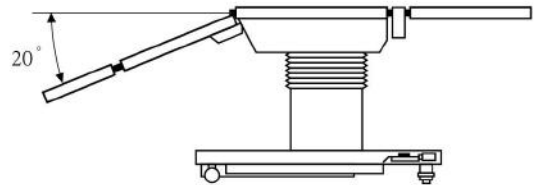
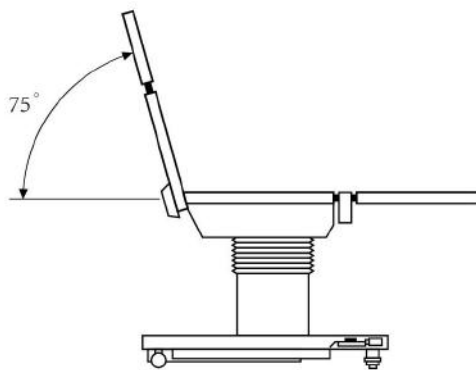

Leg plate(up/down)

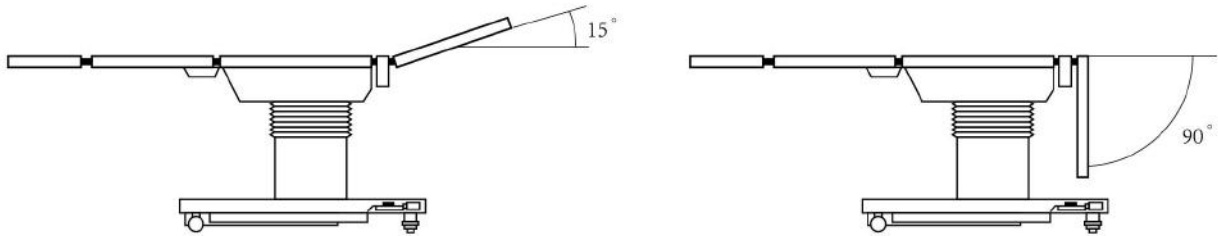

Trendelenburg/Anti-trendelenburg

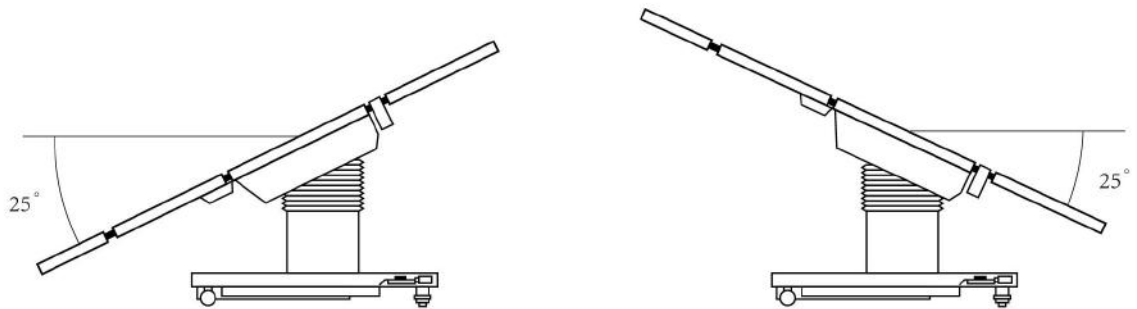

Horizontal sliding

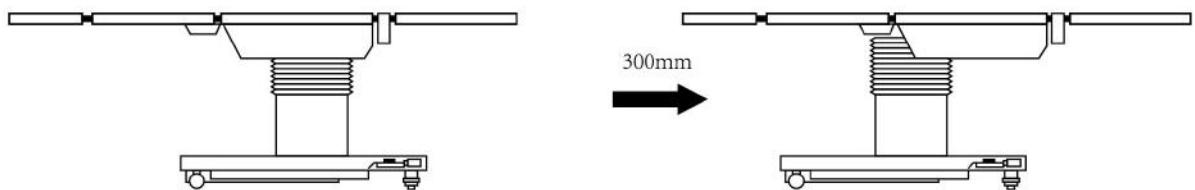

Leg plate outward

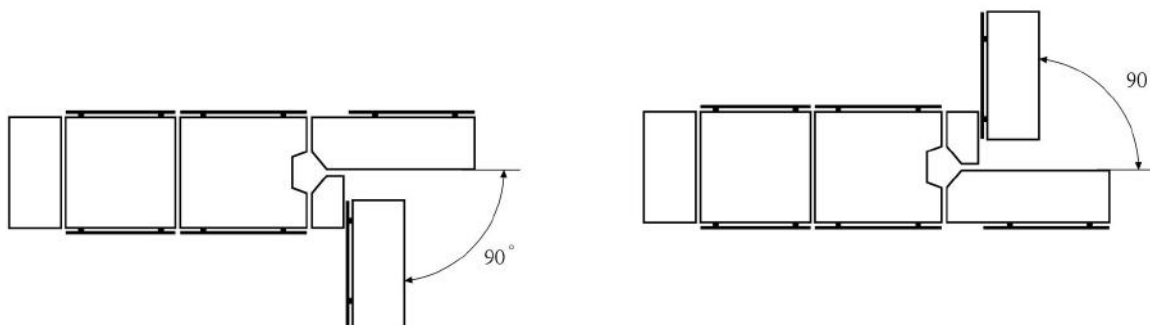

Kidney bridge(up/down)

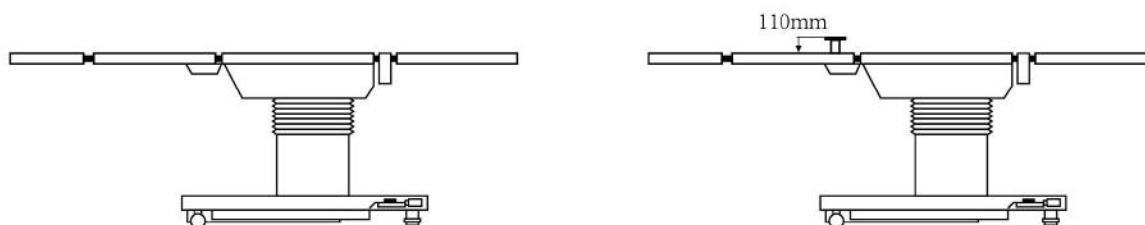

Lateral tilt(left/right)



FOR FURTHER INFORMATION CONTACT
www.medikmedical.com | info@medikmedical.com

medik
+86 139 6223 1292